

# SPECIFICATION SHEET

## Commercial Membrane Systems

### TS Series

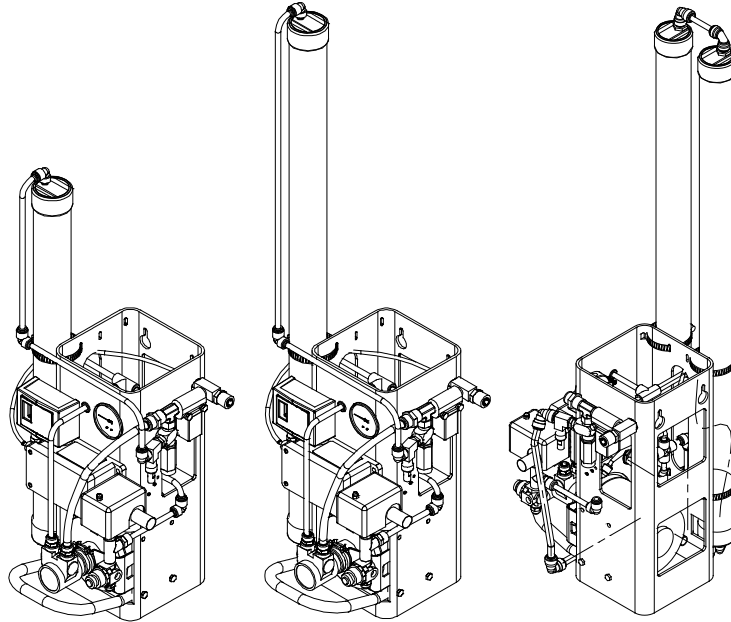



Specifications	TS 300	TS 600	TS 1200
System Size (w x d x h) in	18 x 13 x 31	18 x 13 x 46	18 x 13 x 46
System Size (w x d x h) cm	46 x 33 x 79	46 x 33 x 117	46 x 33 x 117
Membrane Type	RO	RO	RO
EverClean® Rinse	Option	Option	Option
Power (voltage/hz)	120/60 - 230/50	120/60 - 230/50	120/60 - 230/50
Feed Pressure (psi/bar)	15 - 50 / 1 - 3.5	15 - 50 / 1 - 3.5	15 - 50 / 1 - 3.5
Operating Temperature (°F/°C)	35 - 90 / 1.6 – 32.2	35 - 90 / 1.6 – 32.2	35 - 90 / 1.6 – 32.2
Inlet Flow Rate (gpm/Lpm)*	0.42 / 1.6	0.84 / 3.2	1.68 / 6.4
Permeate Flow Rate (gpm/Lpm)*	0.21 / 0.8	0.42 / 1.6	0.84 / 3.2
Reject Flow Rate (gpm/Lpm)*	0.21 / 0.8	0.42 / 1.6	0.84 / 3.2
Rejection Rate –NaCl/CaCO <sub>3</sub>	92% / 98%	92% / 98%	92% / 98%
Daily Production (gpd/Lpd)*	300 / 1,135	600 / 2,271	1,200 / 4,542
TDS (Max) as NaCl mg/L	2,500	2,500	2,500

\*Based on 77°F (25°C), 500 TDS feed, permeate to atmospheric tank, 50 psi (3.45 bar) inlet pressure.